

QUICK START GUIDE

SETTING UP THE NEXA™ NPWT SYSTEM

1 REMOVE THE NEXA™ DEVICE FROM THE CARRY CASE

Unzip the carry case and remove the Nexa™ Device.

2 OPEN GREY COVER & INSERT FLUID CONTAINER PACK

Insert in the orientation shown. Push firmly until it clicks.

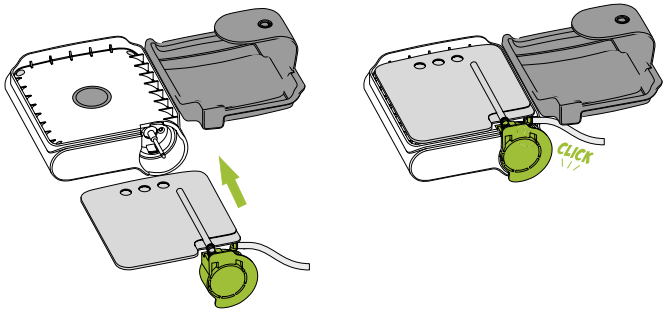

5 CONNECT THE DRESSING TO THE FLUID CONTAINER

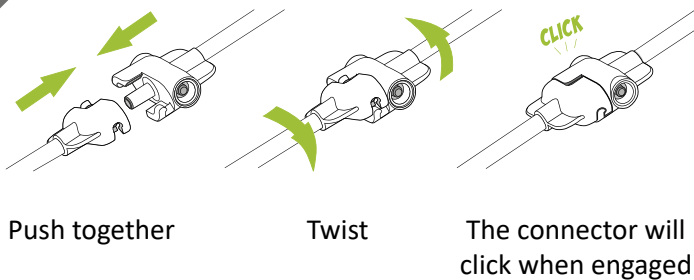

6 POSITION THE NEXA™ DEVICE FOR USE

- For best performance and to enable the maximum fluid containment of 120ml, use the Nexa™ Device **UPRIGHT**, even in the Carry Case.
- Use the buckles and straps to attach to a bed rail or headboard.

7 PRESS THE ON/OFF BUTTON TO START THE DEVICE

The Nexa™ Device is ON when the green light is ON



3 CLOSE GREY COVER

Close the grey cover & latch the strap to the case

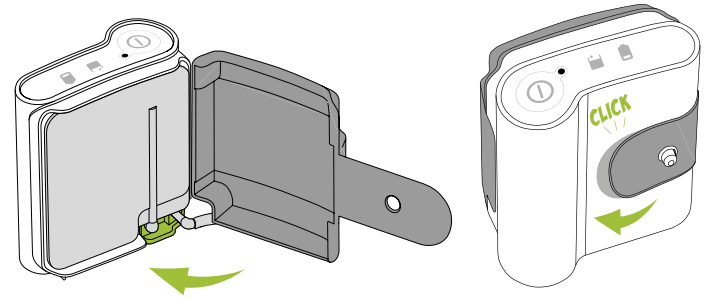

4 PLACE THE CARRY CASE UPRIGHT AND PLACE THE DEVICE INSIDE AS SHOWN BELOW. THEN ZIP IT CLOSED WITH THE TUBE EXITING AS SHOWN.

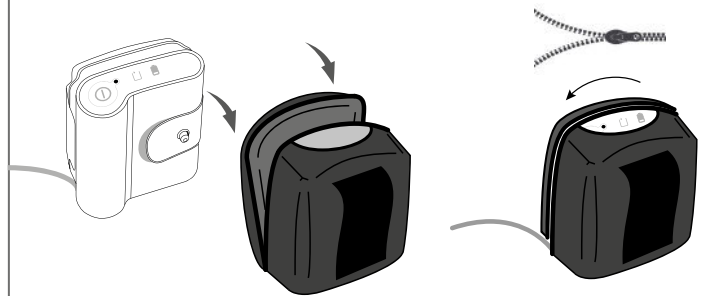

KEEP UPRIGHT USING THE STRAPS TO ATTACH TO A BED FRAME OR OTHER FURNITURE!

8 OPERATION

- The Nexa™ Device will start and run for 3 minutes at a high speed to enable pull down of the Dressing.
- After 3 minutes the Device will slow and run continuously.
- A fully charged Nexa™ Device will run for approximately 10 hrs before requiring charging.

CHARGING THE NEXA™ DEVICE

9 BATTERY LOW INDICATION

The battery is LOW when the orange light is ON



10 CHARGING THE NEXA™ DEVICE

Insert the Nexa™ Power Supply into the socket. If the device is off, press the ON button and the charging light will flash.

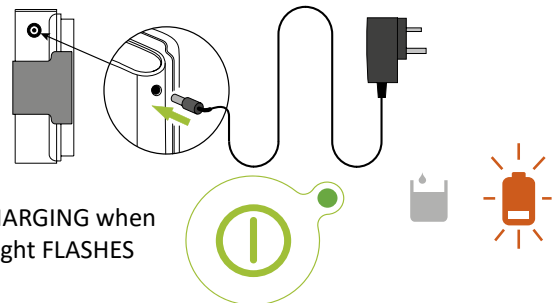

Battery is CHARGING when the orange light FLASHES

CHANGING THE FLUID CONTAINER

11 FLUID CONTAINER FULL

The Fluid Container is FULL or the STRAP is not engaged when the RED light is ON



12 DISCONNECT FLUID CONTAINER FROM DRESSING

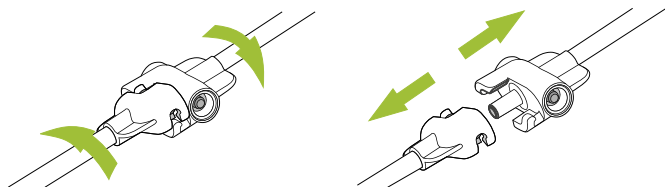

Twist to release

Pull apart

13 REMOVE THE NEXA™ DEVICE FROM CARRY CASE

The Nexa™ Device can be removed from the carry case by unzipping the case and lifting the device out

TROUBLESHOOTING

DEVICE WON'T START

- Check battery is charged or charger is plugged in correctly and switched on at the mains.
- Check grey strap is secured and there are no red lights

DRESSING LEAK

- The Nexa™ Device does not have a leak alarm. The Dynamic Fluid Technology will continue to remove wound fluid irrespective of vacuum levels. This will reduce the potential for skin maceration.
- Observe the foam to determine if there is a leak and have the dressing changed at the next healthcare visit.

BLOCKAGES

A blockage will also cause the device to make an uncharacteristic slapping noise.
To resolve a blockage, check that there is no kinking in the tubing or the tube is occluded.
If there is, either straighten the kink or replace the dressing and/or Fluid Container Pack.

14 OPEN GREY COVER & REMOVE FLUID CONTAINER

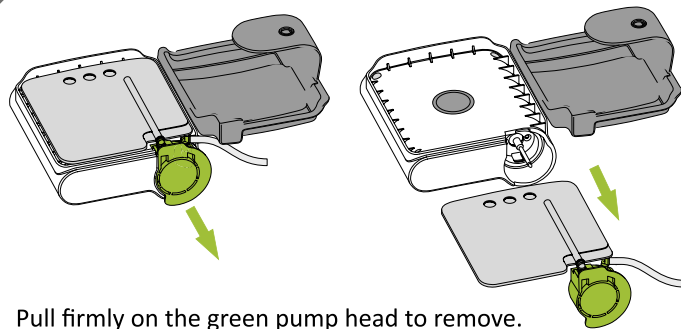

Pull firmly on the green pump head to remove.

15 REPEAT STEPS 1-5 TO INSERT NEW FLUID CONTAINER

CHANGING THE DRESSING

16 CHANGING THE DRESSING

The Nexa™ Dressing is intended to be changed by a health care professional or carer who has experience with wound dressings.

Please refer to the Instructions For Use that is supplied with the Nexa™ Device for more information.

DAYS REMAINING FEATURE

17 Open the grey cover, press and hold the grey button whilst pressing and holding the power button for 8 seconds.

The red light will indicate the number of 10 days and the orange light will indicate the single days.

i.e. 4 red flashes and 2 orange flashes = 42 days remaining.

CONTACT INFORMATION



Manufactured by:
Nexa Medical Limited
Suite 5-6 Willow View, Southfields,
Church Lane, Bournemouth BH22 8TR UK
email: info@nexamedical.com
www.nexamedical.com



Sold & distributed by:
Griffiths and Nielsen Ltd
Maydwell Avenue, Stane Street, Slinfold,
Horsham, West Sussex RH13 0GN
Tel: +44 (0) 1403 799190
Email: medsales@gandn.com
www.gandn.com

CONSULT THE INSTRUCTIONS FOR USE

For a comprehensive manual and important safety information, refer to the Instructions For Use which is provided with the Nexa™ NPWT System.

For further product information, contact a Nexa Medical representative.

For medical questions, contact your doctor, nurse or caregiver.

All trademarks designated herein are property of Nexa Medical Limited and its licensors.

